

**Code:** 91600301  
**Model:** EM0010-RC

## EM0010-RC

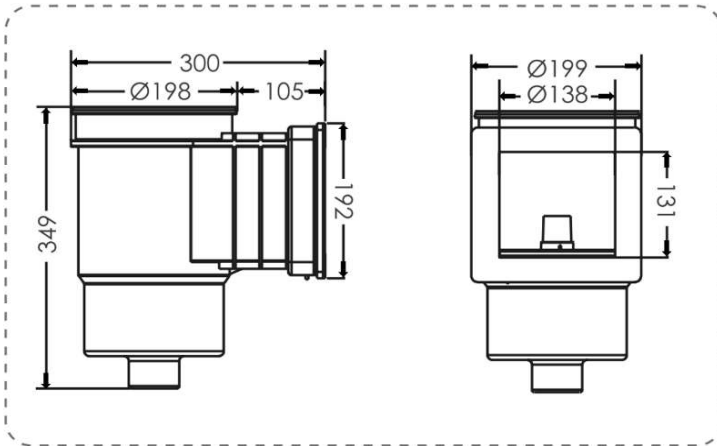

\* dimensions are in mm.



**Product description:** 9.5L Wall Skimmer

**Main Specifications:** Connection: 1.5" Internal Threaded  
 Application: Concrete Pool  
 Flow Rate (L/min): 150

**Certificates:** N/A

**Logistics:**

Box sizes (mm):  
 Units / Box:  
 Volume / Box (m³):  
 Weight / Box (Kg):

length	width	height
370	310	220
1.00		
0.03		
2.3		

\* Individual box.